

# Source identification in practice, two cases with tonal noise

Th.B.J. Campmans

Lichtveld Buis & Partners BV, Nieuwegein, The Netherlands, Email: campmans@lbp.nl



## Introduction

Source identification is of great relevance when annoyance is reported due to tonal noise. Tonal noise is in general extra annoying for the environment. In those cases there is an urge to find the cause of nuisance and solve it. Beside the aspect of the constant frequency, there can be other characteristics that identify the responsible installation that causes the reported annoyance.

In the first case, a source was not only identified by the frequency of the tonal sound, but also by the time pattern in which the installation under consideration is turned on and off. Such time patterns can help in finding a cause, but they can also be misleading. A proper handling of the data is therefore required.

In the second case it was not a real problem to find the responsible installation. The tonal noise started after a well-defined adaptation of the installation. This pointed directly towards the responsible installation. But in order to understand the causing mechanism, the known frequency of the source proved to be helpful in identifying the source mechanism. Such an analysis proves to be a proper basis for designing appropriate noise reducing measures.

## Case 1: Localisation of a tonal source on a foundry

A client was confronted with the measurement results of the local authorities, which reported an exceeding of the permit noise limits in the environment. This exceeding was caused by the fact that the measured noise in the environment contained a pure tone. Dutch regulations prescribe that the total noise level from the plant is given a +5 dB penalty before the level must be adjudged.

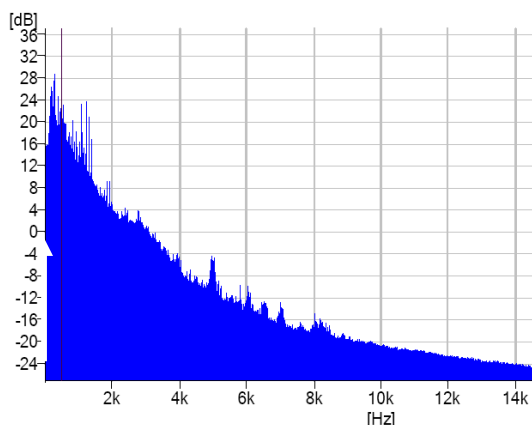

Figure 1: Sound pressure linear spectrum showing a peak of 37,6 dB at 494 Hz.

The noise measurement in the environment of the foundry was adjudged to be tonal assessed according the ISO standard 1996-2 Annex C, may 2001. This measurement showed that at 494 Hz a pure tone was clearly present in the noise. Beside the fact that the noise was tonal, there was a repeating time pattern present in the signal; the signal was repeatedly 6 minutes on and 1 minute off. In the following figure the time pattern is shown from the total sound and the partial contribution of the 500 Hz 1/3<sup>rd</sup>-octave band.

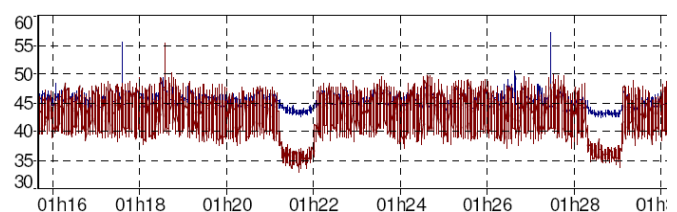

Figure 2: Total sound pressure level and partial contribution of the 500 Hz 1/3rd octave band level

Representatives of the local authorities visited the plant and reported the results. During this visit they noted that the mould cooling fan in a department of the plant should be responsible, since this fan is inside the plant clearly audible as a tonal source, and also has a repetitive time pattern.

A somewhat narrower investigation learned that the mould cooling fan could not be the cause of the tonal sound in the environment: at first the main frequency of this fan was determined to be in the 400 Hz 1/3<sup>rd</sup>-octave band (not 500) and the repetition pattern was 10 minutes on, 5 minutes off.

The responsible installation for the tonal sound could be found easily, since all relevant sound sources had been measured in the past, and this was done in 1/3<sup>rd</sup>-octave bands. From this list of approximately 120 different sources, a search was made for sound sources with a relevant contribution at 500 Hz. This proved to be a ventilation outlet in another part of the plant, with the outlet in the direction of the reported annoyance. Beside the similarity in frequency, the time pattern of this source also fitted with the one measured in the environment. Once this source was found, the use of a simple duct silencer could solve the problem.

## Case 2: Identification of the tonal source on a power plant as basis for the solution.

An annoying tonal sound occurred in the environment of a power plant in Rotterdam. This annoying tone occurred after the retrofit of two energy installations. The retrofit was done in order to improve the speed of switching between different operation modes of the installation from bypass operation to

boiler operation. The change in the installation was done for thermal / material reasons. The system with the location of the flue gas control valves is shown schematically in the figure below, together with a 3D figure of the diffuser. The hot gases come from below, the much colder gases from the right.

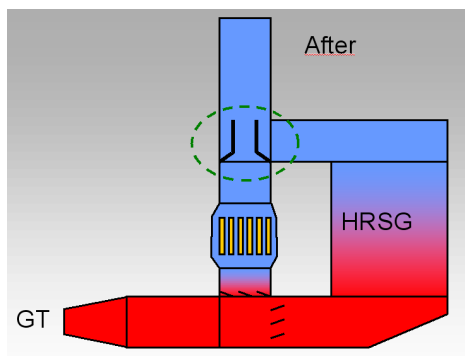

Figure 3: location of diffuser in system

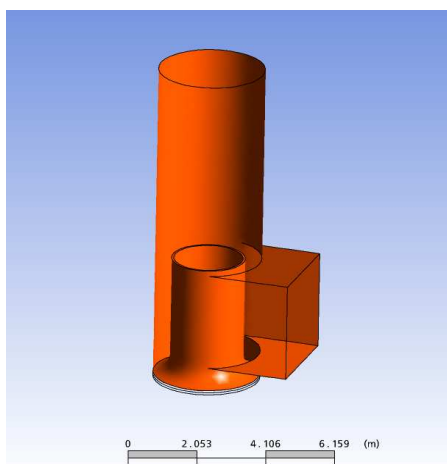

Figure 4: diffuser (drawing by NEM SF)

After installing the diffusers on the two installations, both installations started to radiate an annoying tone in the environment, causing many complaints of the inhabitants. Sound measurements were performed at the different possible operation modes, showing the strong pure tone at boiler operation at approximately 160 Hz.

The relevant operation mode was found by measuring the sound at the different operational modes of the installation, which is shown in figure 5

Due to the complaints, combined with the maintenance planning, a quick solution was necessary.

### Approach

An analysis was made. The cause appeared to be the presence of local flue gas flow turbulences, exciting acoustic resonances of the system. This is caused by the local flow around the newly installed diffuser. In order to solve the problem, it is preferred to know the resonance mechanism of the tone. This can make the solution of the problem easier.

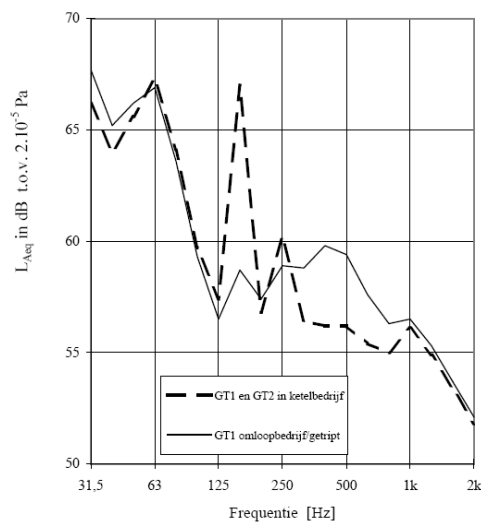

Figure 5: Sound pressure level at boiler and bypass operation showed that boiler operation causes the tone

At first the possibility of Helmholtz resonances was investigated, with the volume existing of the upward gas duct from the valve towards the diffuser, and the throat consisting of the diffuser itself. This mechanism could be eliminated, since this would cause much lower resonance frequencies.

Duct resonances in the length of the stack could also be eliminated as possible causes.

Another possible vibration shapes are acoustic resonances in the cross-sectional plane of the stack. There are several of such resonance shapes. The resonance frequencies  $f_{Gn}$  can be calculated with

$$f_{Gn} = k_n \cdot \frac{c_F}{\pi \cdot d_i} \quad [\text{Hz}] \quad (1)$$

with  $k_n$  = modal factor;  
 $c_F$  = speed of sound in gas,  
 $d_i$  = inner diameter

The resonance shapes and matching modal factors for the first modes are given in figure 6, where the dotted lines represent the “knots” in these shapes.

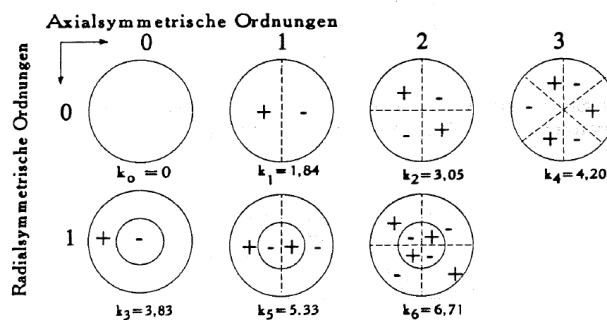
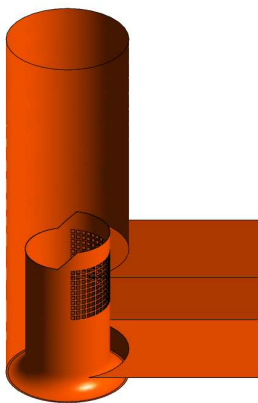

Figure 6: Resonance shapes and modal factors for circular planes (from VDI 3733 Entwurf, 1992)

In the present case, with a diameter of 3,00 m and a temperature of 110 °C ( $C_f = 390$  m/s), calculation proved that the mode belonging to  $k_3 = 3,83$  fitted with the measured tone in the environment.

Based on the knowledge of the exciting mechanism and the resonance mode, it was proposed to change the direction of the local flows at the top of the diffuser to more vertical direction by lengthening the diffuser. This would give rise to a higher flow resistance of the bend, being a disadvantage for the energy efficiency of the installation. This is also a risk for the effectiveness of the noise control measure, since the local speeds would be increased. This could be solved by partially perforating the diffuser.

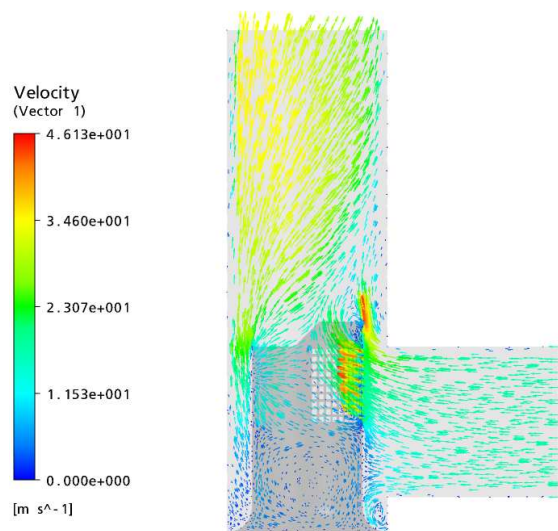

**Figure 7:** Adapted diffuser (by NEM SF)

Since a part of the total flow already enters the diffuser through the perforation, the velocity at the top edge of the diffuser decreases. The lower velocities also decrease the total flow resistance of the installation (with 2,3 mbar = 230 Pa), giving the installation a higher efficiency. Furthermore it was checked that the proposed change of the diffuser was allowed from the thermal point of view, which could be confirmed by the boiler company.

## Results of measure

Noise measurements performed after application of the proposed measures showed a positive result. The tone at 160 Hz was reduced with approximately 6 dB, increasing the annoyance in the environment sufficiently. The measurement results before and after the measure are shown in figure 9. The chosen solution with the reduced flow resistance in the diffuser also will give a slightly higher efficiency of the installation.



**Figure 8:** Calculated flow profile (by NEM SF) after adaptation.

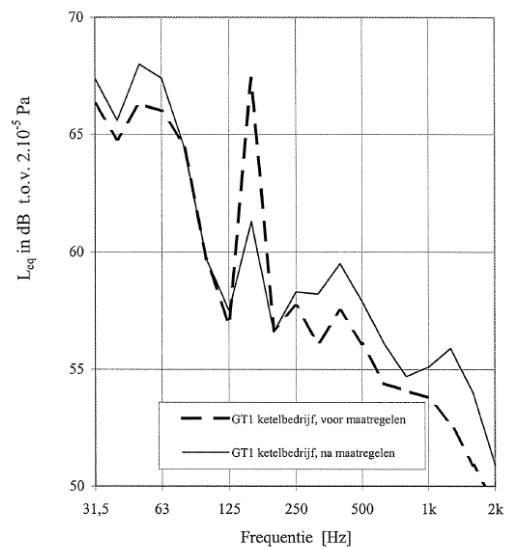

**Figure 9:** Sound pressure level before and after measure

## Final remark

In case of tonal noise, the tone gives relevant information about the source, which can help in the identification of the sound. Other aspects of the sound, such as time patterns can also be useful for recognising the source. The frequency of the sound can also help to understand the source mechanism, which is a proper basis for solving the tonal problem.